

Serie Standard

Modello SBPA Deluxe

Caratteristiche tecniche



Cielo aperto per movimentazione interna
Open top tank for storing and internal handling

Finitura esterna satinata
Finitura interna BA
External satin polished
Internal BA polished

Base palletizzata in acciaio zincato (inox su richiesta)
Galvanised palletised base (inox on request)

Pozzetto stampato nel fondo per svuotamento totale
Bottom with molded pocket to grant full product discharge

Guida-forche per transpallet o carrello elevatore
Palletised base with fork slot

- Base palettisée galvanisée avec guide fourches (inox sur demande)
- Finition extérieure satinée et finition intérieure BA
- Soudage TIG. Nettoyage mécanique de soudures
- Puissard moulé sur le fond pour une évacuation totale
- Vanne de vidange à boule ou papillon max DN 50 (2")

- Base pallet galvanisada con guia-horquillas (inox optional)
- Acabado externo satinado y interno BA
- Soldadura TIG limpieza mecánica de las soldaduras
- Pozo moldeado en el fondo para un vaciado total
- Valvula de descarga esférica o mariposa max. DN 50 (2")

- Palettierte Basis mit Gabelführung (Edelsthal optional)
- Oberfläche innen BA, außen satiniert, Domdeckel elektroliert
- Robotergeschweißte Nähte im WIG Verfahren, Schweißnähte gebeizt und passiviert
- Gestanzter Auslaufschacht am Boden für die komplette Entleerung
- Ausladen mit Kugelhahn oder Scheibenhahn DN 50 (2")

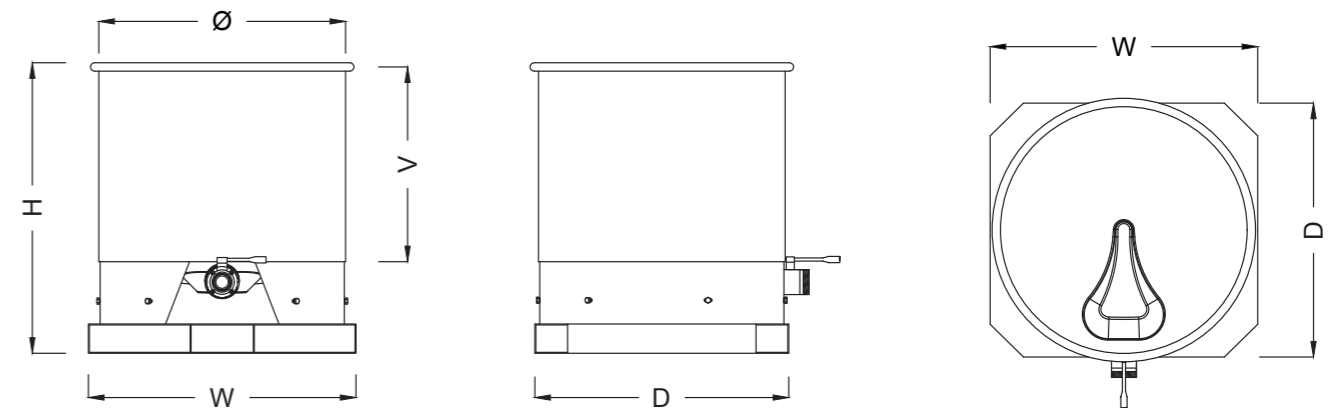

Modello	Capacità lt.	Ø serbatoio	H mm	V mm	Misure gabbia (WxD)	Peso kg
SBPA D 150	173	650	820	500	710x720	ND
SBPA D 300	305	650	1320	1000	710x720	ND
SBPA D 200	206	790	820	500	850x860	ND
SBPA D 450	451	790	1320	1000	850x860	ND
SBPA D 330	330	1000	820	500	1060x1070	ND
SBPA D 700	722	1000	1320	1000	1060x1070	ND
SBPA D 1000	1023	1190	1320	1000	1260x1270	ND
SBPA D 1600	1579	1190	1820	1500	1260x1270	ND
SBPA D 2150	2135	1190	2320	2000	1260x1270	ND
---	---	---	---	---	---	---

AISI 304
AISI 316 (optional)

Spessore 1,2mm (fondo)
1,5mm (viola)
Thickness 1,2mm (bottom)
1,5mm (body)

Saldature TIG
Decapate e spazzolate
TIG Welding
Pickled and passivated

No impilamento
No stacking

particolari - specifics - détails - Detail - particulares



accessori - accessories - accessoires - zubehör - accesorios

